

THIS DOCUMENT IS THE PROPERTY OF
KEYSTONE ELECTRONICS CORP. AND
SHALL NOT BE REPRODUCED, DISTRIBUTED
OR USED AS A BASIS FOR MANUFACTURE
WITHOUT PRIOR WRITTEN PERMISSION
FROM KEYSTONE ELECTRONICS CORP.

REQUIRED SPACING FOR 'AAAA' CLIP

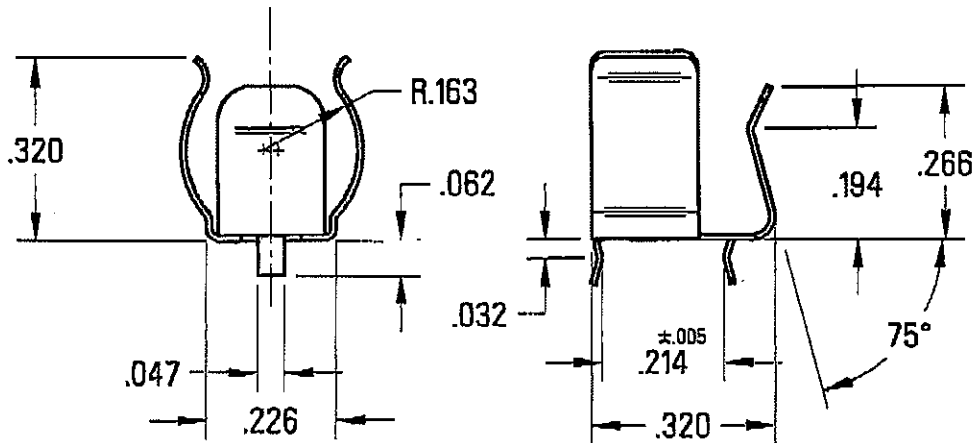
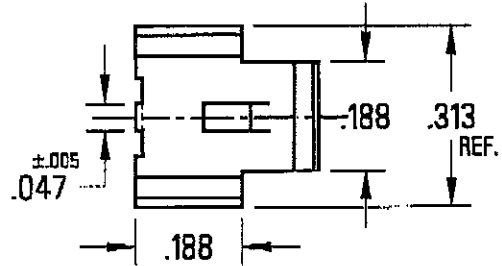
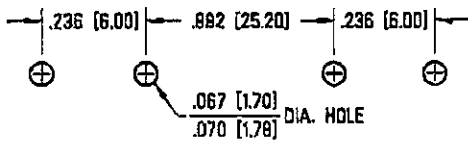

NOTE:

1. ALL INSIDE BEND RADII TO BE .015 UNLESS OTHERWISE SPECIFIED.
2. HEAT TREAT TO SPRING TEMPER
3. FINISH: COMMERCIAL NICKEL PLATE OVER COPPER PLATE

KEYSTONE ELECTRONICS CORP. ASTORIA, N.Y. 11105-2017			
PART NAME		AAAA PC CLIP	
MATERIAL		.010 THICK SPRING STEEL	
FINISH	DRN BY	DATE	
AS NOTED	LARRY	9-25-98	
	APP'D	SCALE	
		NONE	
TOLERANCES	INCH	(MM)	CODE
DECIMAL	±.010	(±)	
ANGULAR	± 1/2°		
UNLESS OTHERWISE SPECIFIED			DWG NO.
			9-82-AAAA

DATE	DESCRIPTION	REV.