

THIS DOCUMENT IS THE PROPERTY OF
KEYSTONE ELECTRONICS CORP. AND
SHALL NOT BE REPRODUCED, DISTRIBUTED
OR USED AS A BASIS FOR MANUFACTURE
WITHOUT PRIOR WRITTEN PERMISSION
FROM KEYSTONE ELECTRONICS CORP.

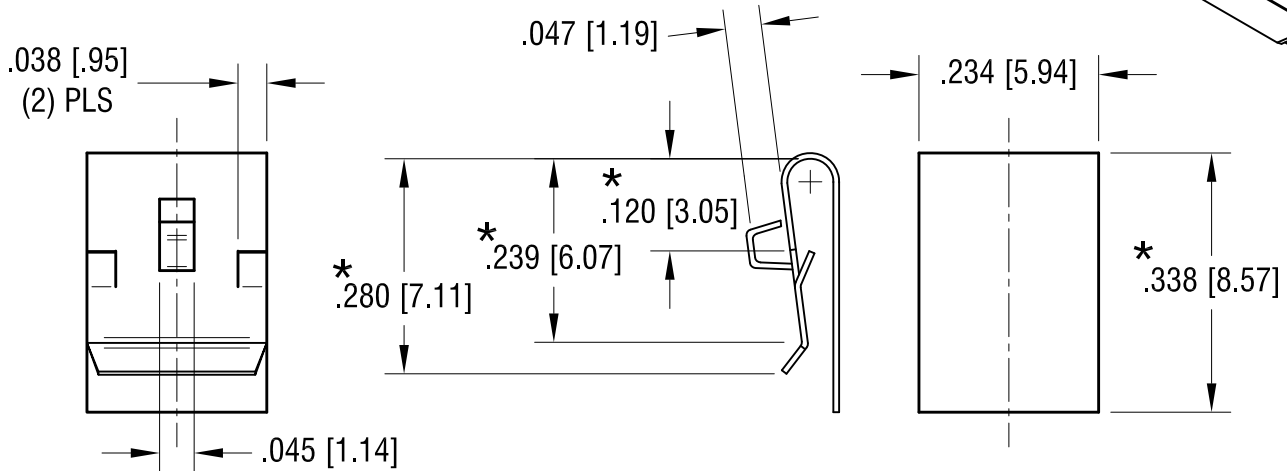
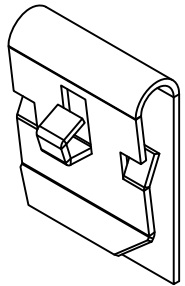

NOTE:

1. HEAT TREAT TO SPRING TEMPER.
2. DESIGNED TO CLIP OVER PANELS FROM .060 [1.52] THRU .070 [1.78] TH'K.
3. * DENOTES $\pm .015$ [$\pm .38$] TOLERANCE

KEYSTONE ELECTRONICS CORP.			
www.keyelco.com • ASTORIA, N.Y. 11105-2017 • Tel (718) 956-8900			
PART NAME			
SINGLE 'AAA'-'AAAA' CONTACT			
MATERIAL			
.010 [.25] TH'K ANNEALED SPRING STEEL			
FINISH		DRN BY	DATE
NICKEL PLATE		NT	6.22.11
		APP'D	SCALE
		LN	3X
TOLERANCES	INCH	[MM]	CODE
DECIMAL	$\pm .010$	[± 0.25]	C
ANGULAR	$\pm 1^\circ$		
UNLESS OTHERWISE SPECIFIED			DWG NO.
			9-238-LD

DATE	DESCRIPTION	REV.