

DATE	DESCRIPTION	REV.
4-21-99	CHANGE HARDNESS FROM C-46-51 A	
		(1)

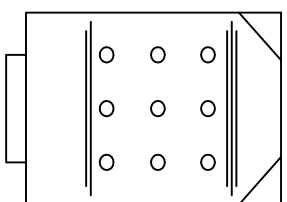
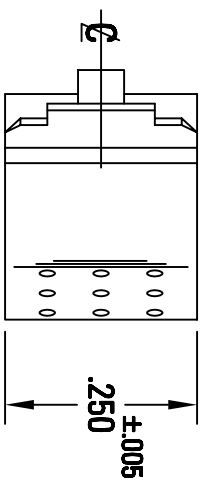
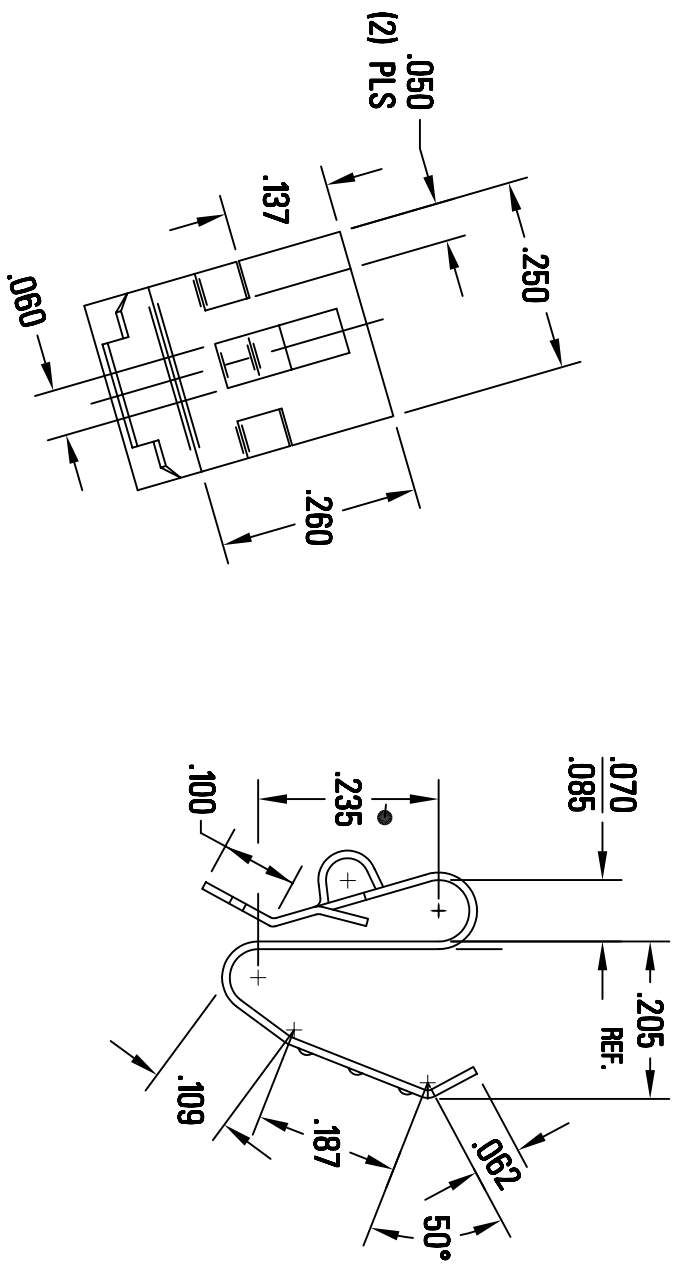

NOTE:

1. HEAT TREAT TO ROCKWELL C42-C46 (1)
2. FINISH: COMMERCIAL NICKEL PLATE
NICKEL PLATE .00015 MIN. OVER
COPPER PLATE .00005 MIN. AND
BAKE TO RELIEF ANY HYDROGEN EMBRITTLEMENT

KEYSTONE ELECTRONICS CORP.			
ASTORIA, N.Y. 11105-2017			
PART NAME 'AAA' 'N' SINGLE CONTACT			
MATERIAL .006 TH'K 1075 ANNEALED SPRING STEEL			
FINISH AS NOTED			
TOLERANCES	INCH	[MM]	CODE
DECIMAL	±.010	[±]	C
ANGULAR	±1/2°		
UNLESS OTHERWISE SPECIFIED			DWG NO.
			9-204-006
DRN BY	LARRY	DATE	7/6/98
APP'D		SCALE	4X

THIS DOCUMENT IS THE PROPERTY OF KEYSTONE ELECTRONICS CORP. AND SHALL NOT BE REPRODUCED, DISTRIBUTED OR USED AS A BASIS FOR MANUFACTURE WITHOUT PRIOR WRITTEN PERMISSION FROM KEYSTONE ELECTRONICS CORP.