

2.140 MAX.

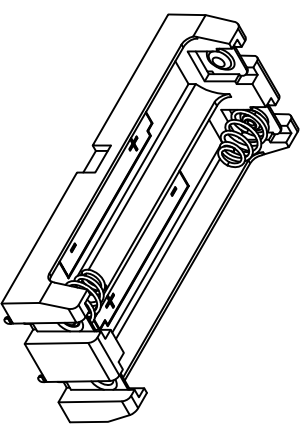
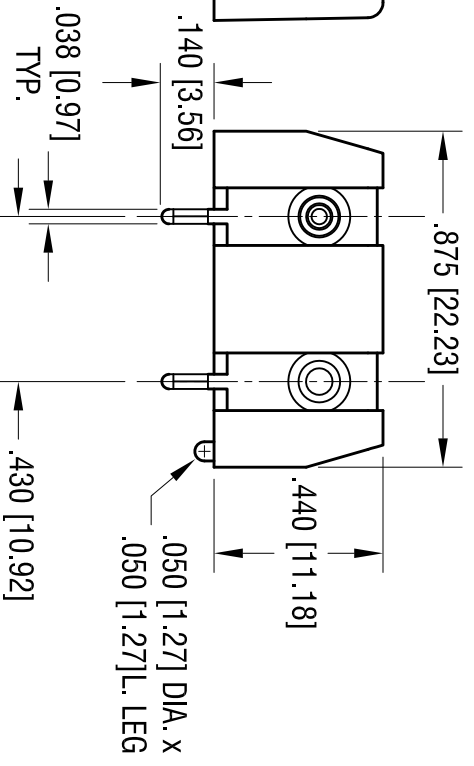
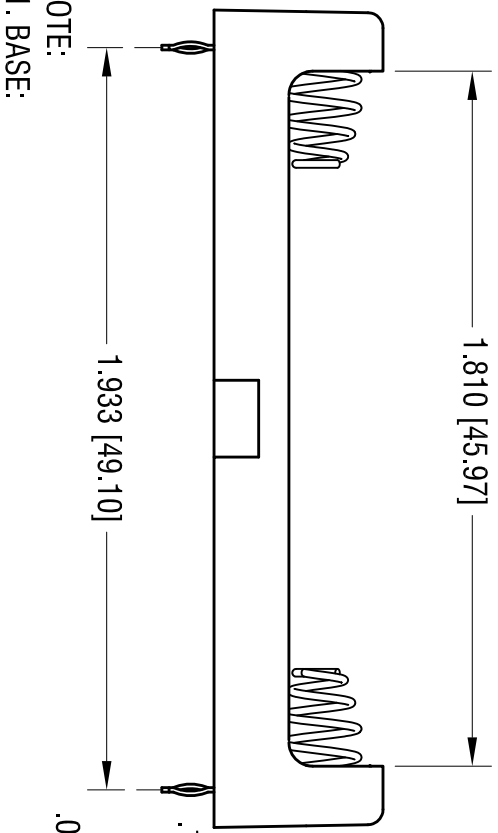
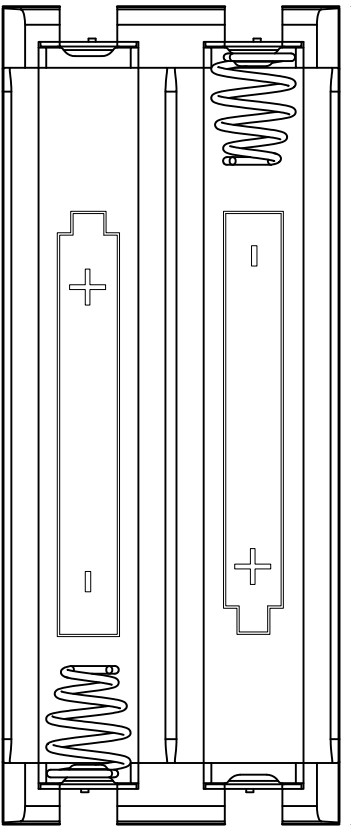

ACTUAL SIZE

- NOTE:
1. BASE: MAT'L: HEAT RESISTANCE NYLON STANYL 46 OR EQUIVALENT
 2. CONTACT: MAT'L: .012 [0.30] THK PHOSPHOR BRONZE FINISH: TIN NICKEL PLATE.

DATE	DESCRIPTION	REV.

KEYSTONE ELECTRONICS CORP.
 www.keystec.com • ASTORIA, N.Y. 11105-2017 • Tel (718) 956-8900

PART NAME
 THM DUAL BATTERY HOLDER, AAA

MATERIAL
 AS NOTED

FINISH
 AS NOTED

TOLERANCES	INCH	[MM]	CODE	DWG NO.
DECIMAL	± .010	[± 0.25]	C	9-1023-SPR
ANGULAR	± 1°			

THIS DOCUMENT IS THE PROPERTY OF KEYSTONE ELECTRONICS CORP. AND SHALL NOT BE REPRODUCED, DISTRIBUTED OR USED AS A BASIS FOR MANUFACTURE WITHOUT PRIOR WRITTEN PERMISSION FROM KEYSTONE ELECTRONICS CORP.

DRN BY	DATE
NT	10.03.13
APP'D	SCALE
LN	2X