

NO.

REV.

P/No	A	C	D	L
73	.750	1.750	.500	9.00
74	.937	1.870	.453	8.50
75	1.375	2.500	.562	8.50
76	1.500	2.615	.557	8.50
77	2.500	3.429	.464	7.00

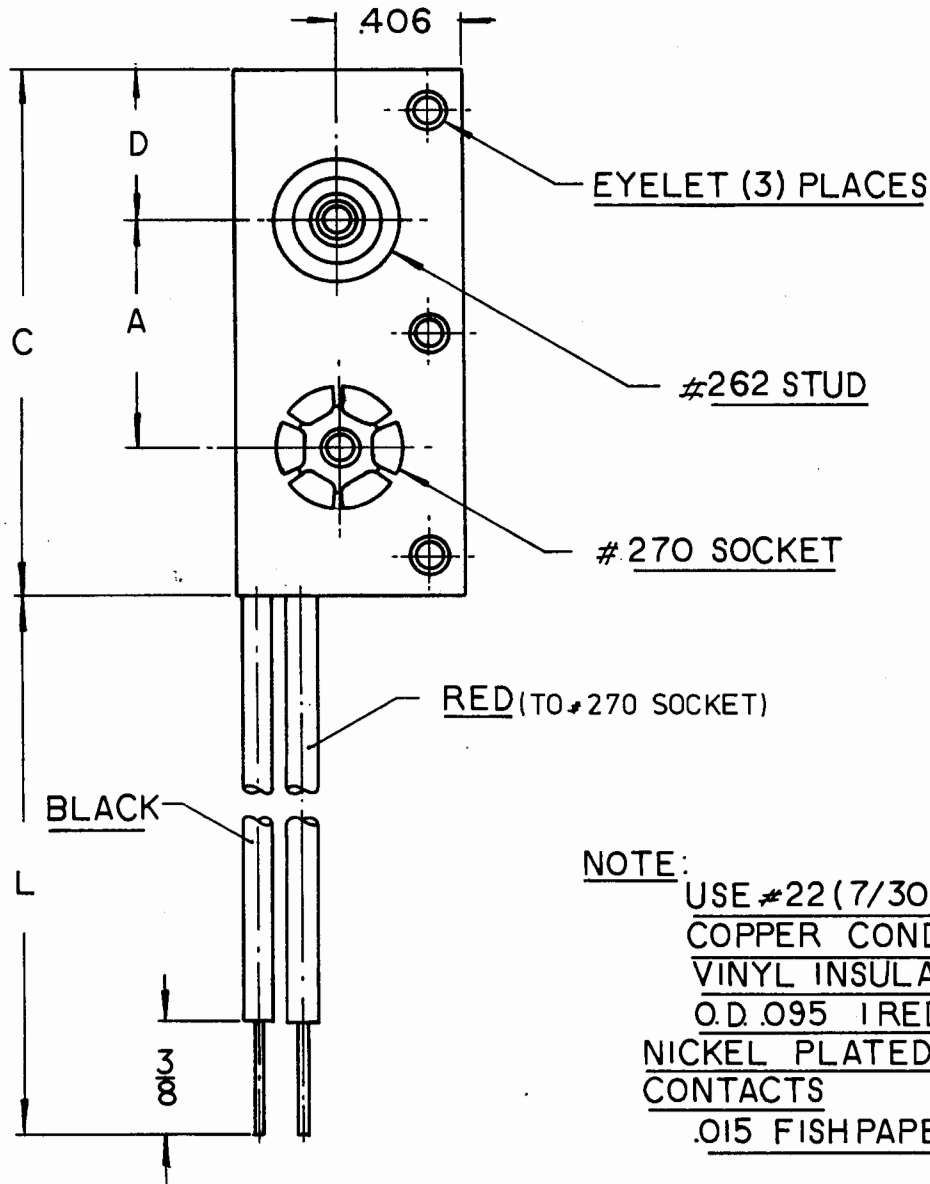
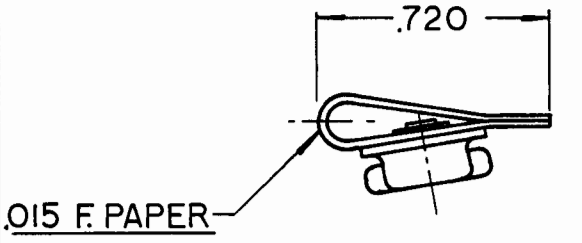

NOTE:
USE #22 (7/30) TINNED
COPPER CONDUCTORS
VINYL INSULATION
O.D. .095 1 RED & 1 BLACK
NICKEL PLATED STEEL
CONTACTS
.015 FISH PAPER

KEYSTONE ELECTRONICS CORP.
 NEW YORK, N.Y. 10012

PART NAME			BATTERY STRAP		
MATERIAL			AS NOTED		
FINISH	DRAWN BY	LN.	DATE	10.20.81	
	APPROVED	AA.	SCALE	—	
TOLERANCES			DWG. NO.		
FRACTIONAL ± .015			73, 74, 75, 76, 77		
DECIMAL ± .005 ANGULAR ± 1/2°			UNLESS OTHERWISE NOTED		

DATE	REVISION	ISSUE