

THIS DOCUMENT IS THE PROPERTY OF KEYSTONE ELECTRONICS CORP. AND SHALL NOT BE REPRODUCED, DISTRIBUTED OR USED AS A BASIS FOR MANUFACTURE WITHOUT PRIOR WRITTEN PERMISSION FROM KEYSTONE ELECTRONICS CORP.

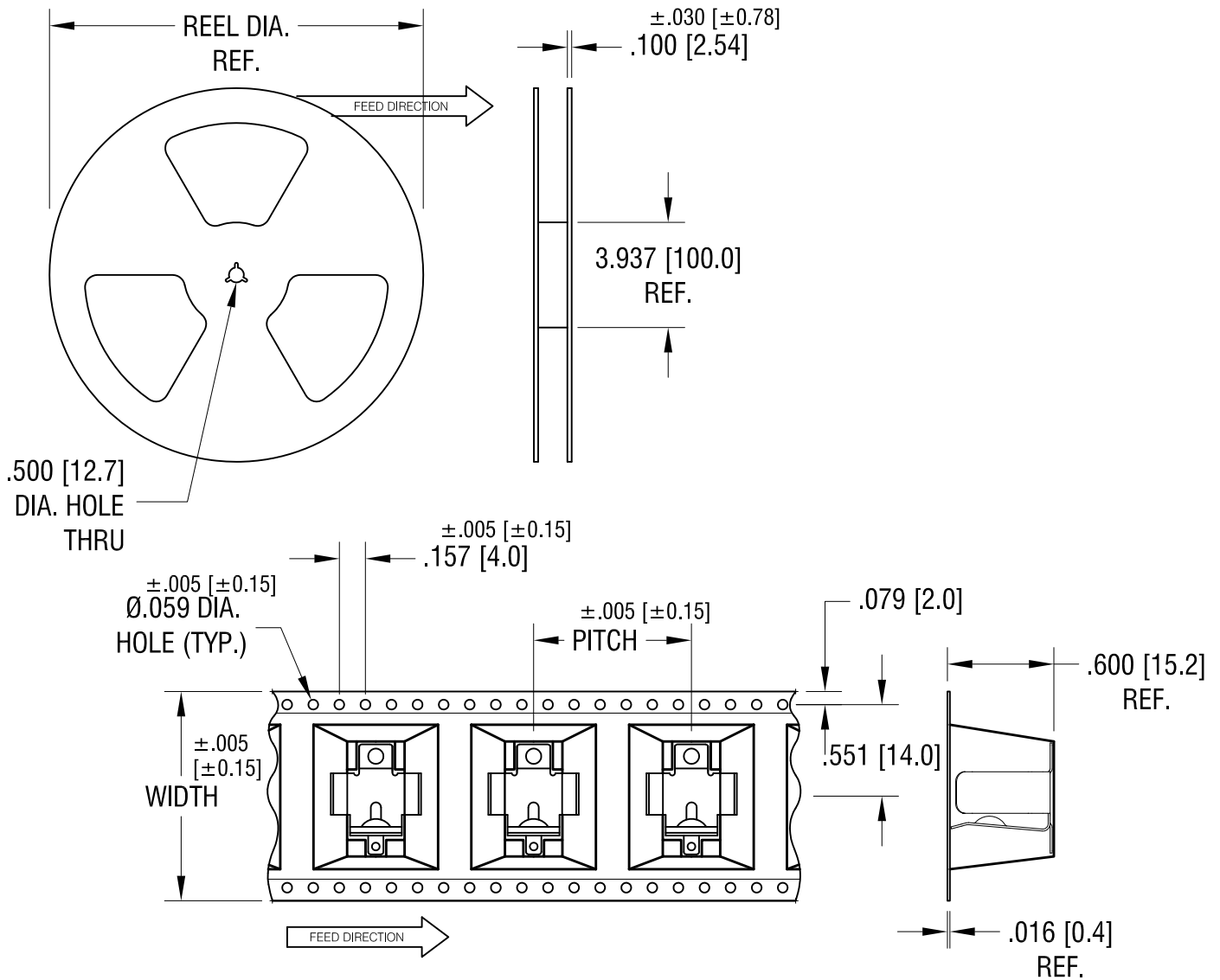

**NOTES:**

**TAPE AND REEL SPECIFICATIONS:**

**1. TAPE:**

MAT'L - ALL CONDUCTIVE POLYSTYRENE CARRIER  
 ANSI/EIA-481 STANDARD  
 1.260 [32.0] WIDE; .950 [24.0] PITCH

**2. REEL:**

15.0 [380.8] DIA. 150 PIECES  
 OF PART NO. 553 PER REEL.

|         |                          |      |
|---------|--------------------------|------|
| 4.12.12 | CHANGE AS PER ECN 12-048 | B    |
| 3.07.11 | CHANGE AS PER ECN 11-029 | A    |
| DATE    | DESCRIPTION              | REV. |

|   |                 |        |              |
|---|-----------------|--------|--------------|
| <b>KEYSTONE ELECTRONICS CORP.</b>                               |                 |        |              |
| www.keyelco.com • ASTORIA, N.Y. 11105-2017 • Tel (718) 956-8900 |                 |        |              |
| PART NAME   |                 |        |              |
| "A" & "AA" BATTERY HOLDER, ON TAPE                              |                 |        |              |
| MATERIAL  |                 |        |              |
| AS NOTED  |                 |        |              |
| FINISH  |                 | DRN BY | DATE         |
| AS NOTED  |                 | NT     | 7.20.09      |
|   |                 | APP'D  | SCALE        |
|   |                 | LN     | X            |
| TOLERANCES  | INCH [MM]       | CODE   | DWG NO.      |
| DECIMAL   | ± .015 [± 0.38] | C/M    | <b>553TR</b> |
| ANGULAR   | ± 1°            |        |              |
| UNLESS OTHERWISE SPECIFIED                                      |                 |        |              |