

THIS DOCUMENT IS THE PROPERTY OF KEYSTONE ELECTRONICS CORP. AND SHALL NOT BE REPRODUCED, DISTRIBUTED OR USED AS A BASIS FOR MANUFACTURE WITHOUT PRIOR WRITTEN PERMISSION FROM KEYSTONE ELECTRONICS CORP.

MOUNTING PAD LAYOUT. REQUIRED SPACING FOR 'A' OR 'AA' BATTERIES

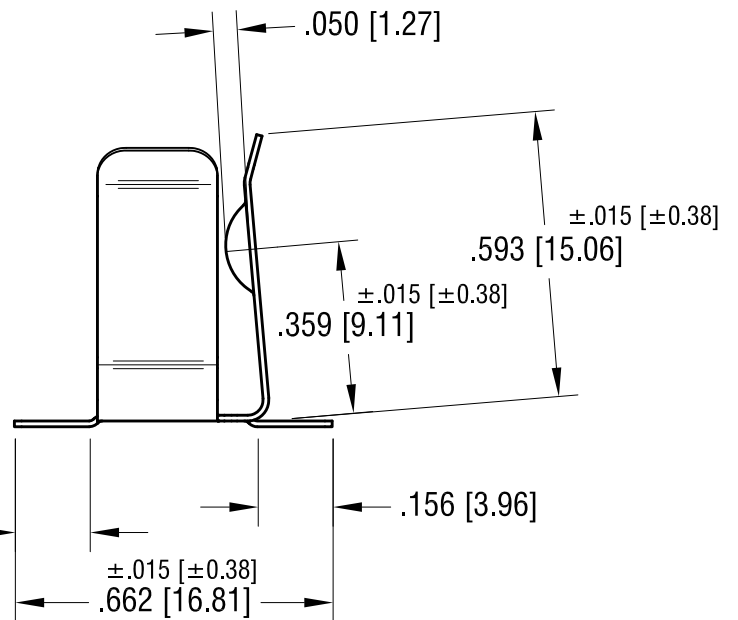
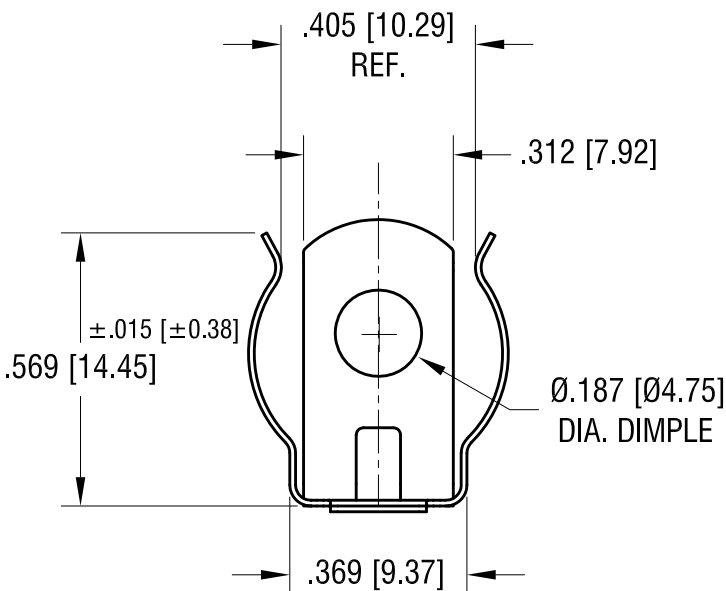
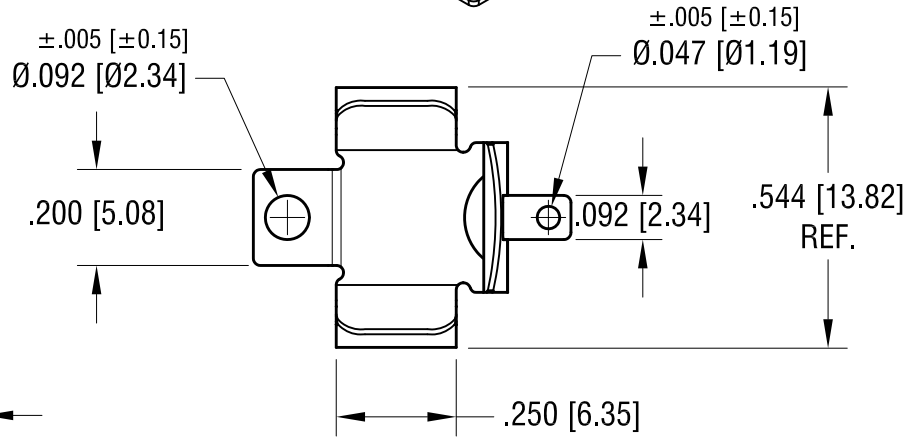
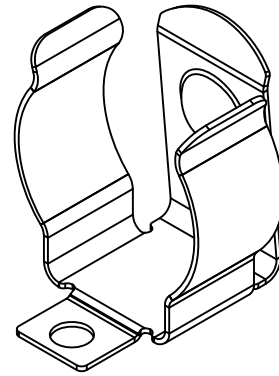
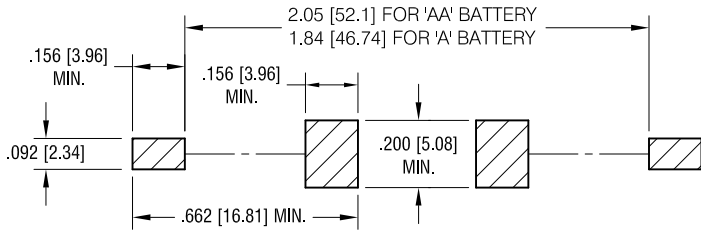

NOTE:

1. HEAT TREAT TO SPRING TEMPER.

KEYSTONE ELECTRONICS CORP.

www.keyelco.com • ASTORIA, N.Y. 11105-2017 • Tel (718) 956-8900

PART NAME		'A' & 'AA' BATTERY HOLDER	
MATERIAL		.012 [.30] TH'K ANNEALED SPRING STEEL	
FINISH	DRN BY	DATE	
MATTE TIN PLATE	NT	7.20.09	
	APP'D	SCALE	
		2.5X	
TOLERANCES	INCH	[MM]	CODE
DECIMAL	±.010	[±0.25]	C
ANGULAR	± 1°		
UNLESS OTHERWISE SPECIFIED			DWG NO.
			553

10.20.09	CHANGE AS PER ECN 09-153	A
DATE	DESCRIPTION	REV.