

DATE	DESCRIPTION	REV.
9.10.99	CHANGE AS PER ECN 99-64	A
8.10.00	CHANGE AS PER ECN 00-079	B
5.13.03	CHANGE AS PER ECN 03-038	C
9.11.09	CHANGE AS PER ECN 09-124	D
7.06.10	CHANGE AS PER ECN 10-050	E
12.05.12	CHANGE AS PER ECN 12-098	F
10.01.14	CHANGE AS PER ECN 14-106	G
12.28.15	CHANGE AS PER ECN 15-148	H

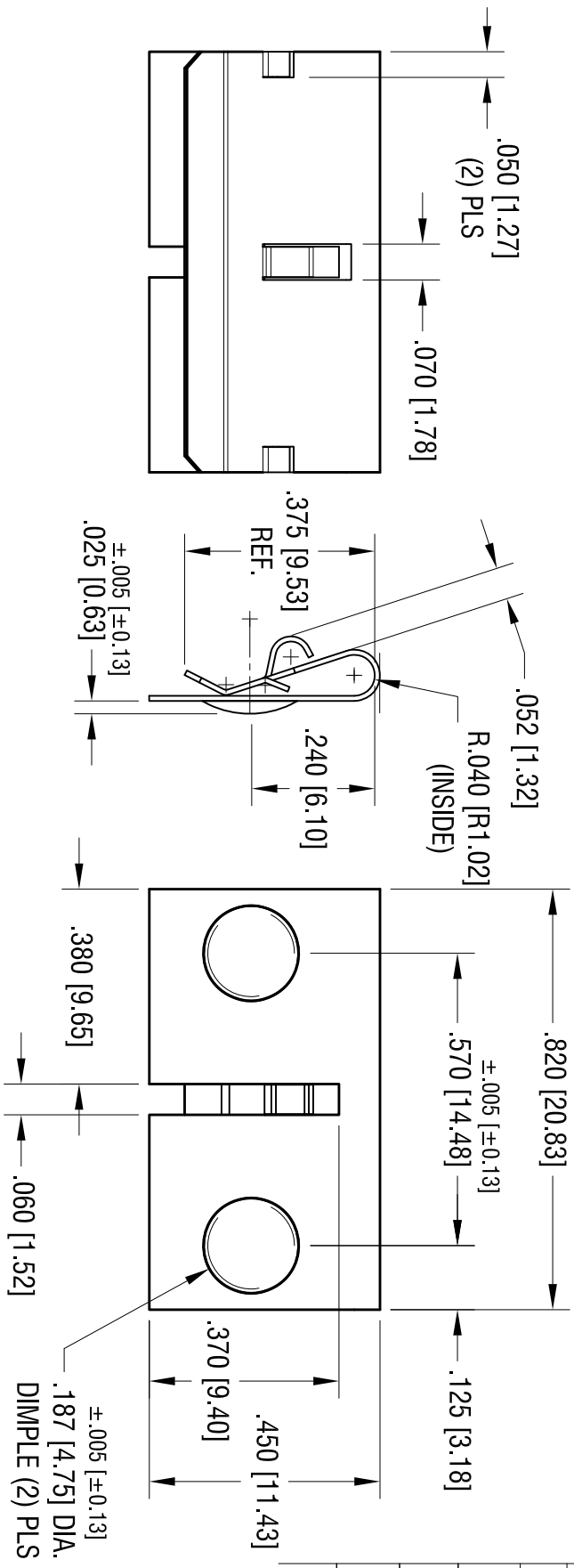

NOTE:
1. DESIGNED TO CLIP OVER PANELS
FROM .060 [1.52] THRU .070 [1.78] THK.

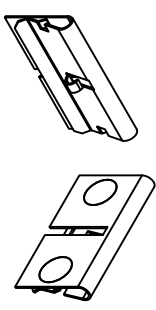

ACTUAL SIZE

KEYSTONE ELECTRONICS CORP.			
www.keystone.com • ASTORIA, N.Y. 11105-2017 • Tel (718) 956-8900			
PART NAME 1AA MALE/MALE BATTERY CONTACT			
MATERIAL .010 [0.25] THK STAINLESS STEEL			
FINISH NICKEL PLATE		DRN BY BOONE	DATE 3.16.99
TOLERANCES DECIMAL ± .010 [±.025] ANGULAR ± 1°		CODE C	DWG NO. 292
THIS DOCUMENT IS THE PROPERTY OF KEYSTONE ELECTRONICS CORP. AND SHALL NOT BE REPRODUCED, DISTRIBUTED OR USED AS A BASIS FOR MANUFACTURE WITHOUT PRIOR WRITTEN PERMISSION FROM KEYSTONE ELECTRONICS CORP.			