

THIS DOCUMENT IS THE PROPERTY OF
KEYSTONE ELECTRONICS CORP. AND
SHALL NOT BE REPRODUCED, DISTRIBUTED
OR USED AS A BASIS FOR MANUFACTURE
WITHOUT PRIOR WRITTEN PERMISSION
FROM KEYSTONE ELECTRONICS CORP.

ACTUAL SIZE

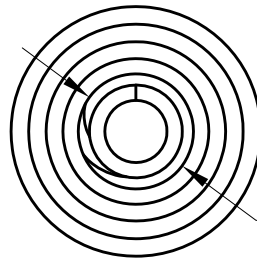

$+.005 [+0.15]$
 $-.000 [-.000]$
 $\text{Ø}.300 [\text{Ø}7.62]$ DIA.

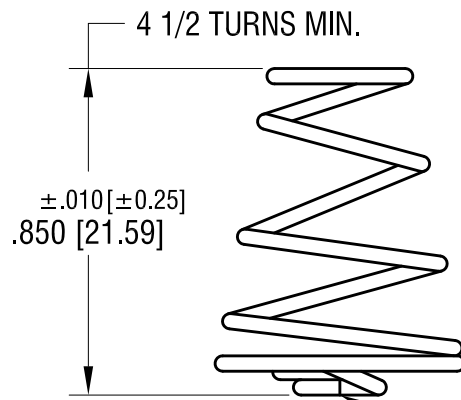
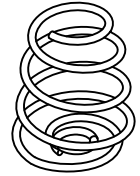

SURFACE MUST BE FLAT
& PERPENDICULAR TO AXIS

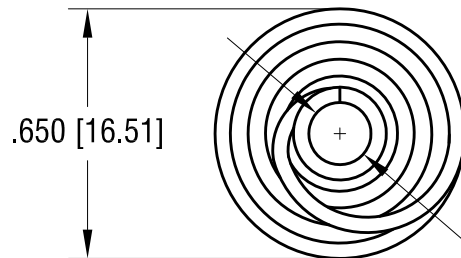

$.650 [16.51]$

$+.002 [+0.05]$
 $-.003 [-0.07]$
 $\text{Ø}.162 [\text{Ø}4.11]$ DIA.

KEYSTONE ELECTRONICS CORP.

www.keyelco.com • ASTORIA, N.Y. 11105-2017 • Tel (718) 956-8900

PART NAME		COIL SPRING	
MATERIAL		.040 [1.02] DIA. MUSIC WIRE	
FINISH		DRN BY	DATE
NICKEL PLATE		BOONE	11.11.93
		APP'D	SCALE
		LN	2X
TOLERANCES	INCH [MM]	CODE	DWG NO.
DECIMAL	$\pm .005 [\pm 0.13]$	C	211-D
ANGULAR	$\pm 1^\circ$		
UNLESS OTHERWISE SPECIFIED			

12.18.12	CHANGE AS PER ECN 12-159	A
DATE	DESCRIPTION	REV.